

TELESCOPIC ARM FOR FORKLIFT  
BRAS TÉLÉSCOPIQUE À FIXATION SUR FOURCHES DE CHARIOT ÉLEVATEUR

Hydraulic extension for ELSPAFOTH type  
On demand  
Extension hydraulique pour type ELSPAFOTH  
Sur demande



Bras télescopique hydraulique type: ELSPAFOTH - Hydraulic telescopic arm type: ELSPAFOTH

Le chargeur télescopique augmente la portée de votre élévateur  
The extensible crane arm increases the reach of the forklift truck

- Construction en acier. | Steel construction.
- Partie télescopique rétractable, extensible sur 8 positions.  
Extension arm is positioned inside the shell and can be extended in 8 steps to reach full length.
- Sécurisé par chaîne contre le glissement inintentionnel. | Secured by chain to prevent slipping.
- 2 crochets porte charge. | 2 rotating hooks.

ELSPAFOTH

Type ELSPAFOT extensible - Type ELSPAFOT extended

Type ELSPAFOT

Dimensions intérieures des fourreaux (mm)  
Fork sleeve inside dimensions in mm

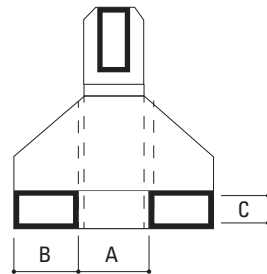

Type	A	B	C
ELSPAFOT 2,5	106	184	84
ELSPAFOT 5,0	116	184	84
ELSPAFOT 2,5	156	184	84
ELSPAFOT 5,0	166	184	84

Type ELSPAFOTH

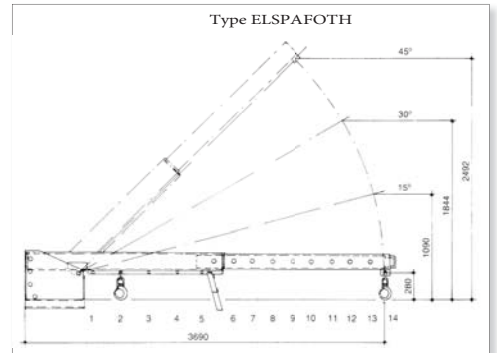

Description

Type ELSPAFOT

- Construction rigide.

Type ELSPAFOTH

- Réglable sur 3 hauteurs différentes, chaque position est sécurisée par des goujons.

Description

Type ELSPAFOT

- Rigid construction.

Type ELSPAFOTH

- Variable working height and can be fixed in each of the positions using the pin provided.

Type Type	Position Position	Distance (mm) Distance (mm)														Dimension (LxPxH) Dimensions (LxWxH)	Poids Weight
		1	2	3	4	5	6	7	8	9	10	11	12	13	14		
		Kg	Kg	Kg	Kg	Kg	Kg	Kg	Kg	Kg	Kg	Kg	Kg	Kg	Kg	mm	Kg
ELSPAFOT 2,5	CMU   Max cap.	2500	2500	2500	1800	1400	1200	1050	950	850	770	700	650	600	560	2160 x 490 x 480	175
ELSPAFOT 5,0	CMU   Max cap.	5000	3550	2750	2250	1950	1700	1550	1400	1300	1200	1150	1050	1000	950	2160 x 500 x 525	195

Veillez à la charge admissible de votre chariot élévateur ! | Remember to check the load capacity of the forklift truck in question!

Type Type	Position Position	Distance (mm) Distance (mm)														Dimension (LxPxH) Dimensions (LxWxH)	Poids Weight
		1	2	3	4	5	6	7	8	9	10	11	12	13	14		
		Kg	Kg	Kg	Kg	Kg	Kg	Kg	Kg	Kg	Kg	Kg	Kg	Kg	Kg	mm	Kg
ELSPAFOTH 2,5	CMU   Max cap.	2500	2500	2500	1800	1400	1200	1050	950	850	770	700	650	600	560	2210 x 540 x 555	218
ELSPAFOTH 5,0	CMU   Max cap.	5000	3550	2750	2250	1950	1700	1550	1400	1300	1200	1150	1050	1000	950	2210 x 550 x 600	250

Veillez à la charge admissible de votre chariot élévateur ! | Remember to check the load capacity of the forklift truck in question!

OPTIONS

Peinture | Painting

RAL 2000		RAL 3000		RAL 5012
RAL 6011		RAL 7005		Galvanisé   Galvanized

Extension | Extension

Extended hydraulically type ELSPAFOTH

Extension hydraulique pour type ELSPAFOTH  
Sur demande

On request

Price/Prix:

# BRAS DE LEVAGE À FIXATION SUR FOURCHES DE CHARIOT ÉLEVATEUR LIFTING ARM FOR FORKLIFT

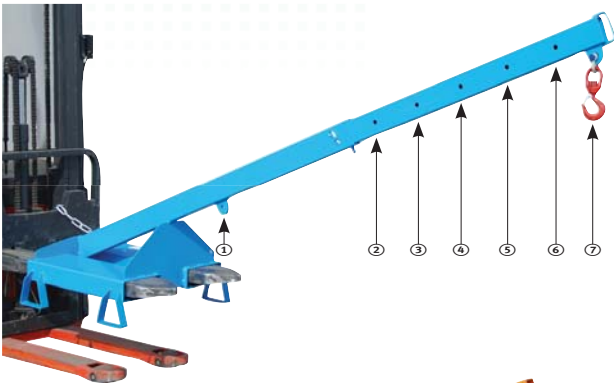

Type ELSPAFOCT 25

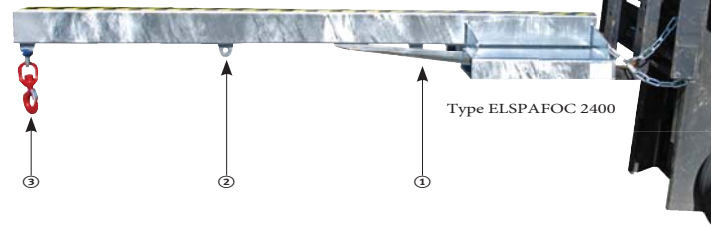

Type ELSPAFOC 2400



Type ELSPAFOC 25

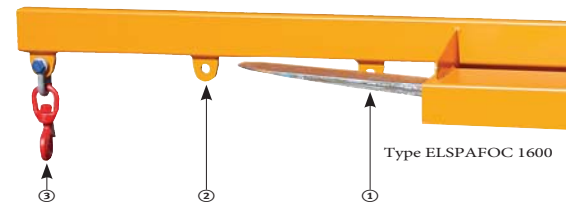
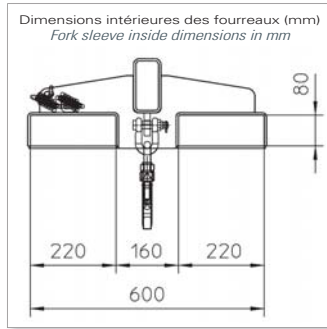

Type ELSPAFOC 1600

## Description

La potence transforme le chariot élévateur en grue mobile

- Construction en acier.
- Fourreaux.
- Compatibles gerbeurs.
- Sécurité anti-glissement par chaînes.
- 1 crochet à émerillon avec linguet de sécurité.

Type ELSPAFOC 1600/2400

- Versions rigides.

Type ELSPAFOC 25

- Versions rigides.
- Angle d'inclinaison 25°.
- Pieds support, hauteur de passage 100 mm.

Type ELSPAFOCT 25

- Angle d'inclinaison 25°.
- Téléscopique, chaque position sécurisée par des goujons.
- Pieds support, hauteur de passage 100 mm.

## Description

The loading arm increases the reach of the forklift truck

- Steel construction.
- Fork sleeves for pick-up.
- Also for straddle stackers.
- Secured by chain to prevent slipping.
- 1 rotating hook.

Type ELSPAFOC 1600/2400

- Rigid construction.

Type ELSPAFOC 25

- Rigid construction.
- Inclination 25°.
- With stirrups 100 mm ground leeway.

Type ELSPAFOCT 25

- Inclination 25°.
- Variable working height, can be fixed in each position.
- With stirrups 100 mm ground leeway.

Type	Longueur de base (mm) Basic length in mm	Position	1	2	3	4	5	6	7	Poids laqué (kg) Weight lacquered (kg)
ELSPAFOC 1600-1,0	1600	Distance   Distance   mm Charge adm.   Max. load   kg	780 1000	1165 350	1550 200					42
ELSPAFOC 2400-1,0	2400	Distance   Distance   mm Charge adm.   Max. load   kg	780 1000	1565 200	2350 100					49
ELSPAFOC 1600-2,5	1600	Distance   Distance   mm Charge adm.   Max. load   kg	780 2500	1165 850	1550 500					73
ELSPAFOC 2400-2,5	2400	Distance   Distance   mm Charge adm.   Max. load   kg	780 2500	1565 500	2350 250					88
ELSPAFOC 1600-5,0	1600	Distance   Distance   mm Charge adm.   Max. load   kg	780 5000	1165 1700	1550 1000					104
ELSPAFOC 2400-5,0	2400	Distance   Distance   mm Charge adm.   Max. load   kg	780 5000	1565 1000	2350 500					124
ELSPAFOC 25-1,0	1600	Distance   Distance   mm Charge adm.   Max. load   kg	875 1000	1600 300						47
ELSPAFOCT 25-1,0	1600	Distance   Distance   mm Charge adm.   Max. load   kg	875 1000	1600 300	1780 225	1960 200	2140 175	2320 150	2500 125	55

## OPTIONS

### Peinture | Painting

RAL 2000  
RAL 6011

RAL 3000  
RAL 7005

RAL 5012  
Galvanisé | Galvanized

# Forklift Lifting Equipment custom made

Forklifts and lifting devices are made to order and therefore the design and lifting capacity can be modified to suit your individual requirements.



PALONNIER POUR FOURCHES DE CHARIOT ÉLÉVATEUR  
LIFTING BEAM FOR FORKLIFT

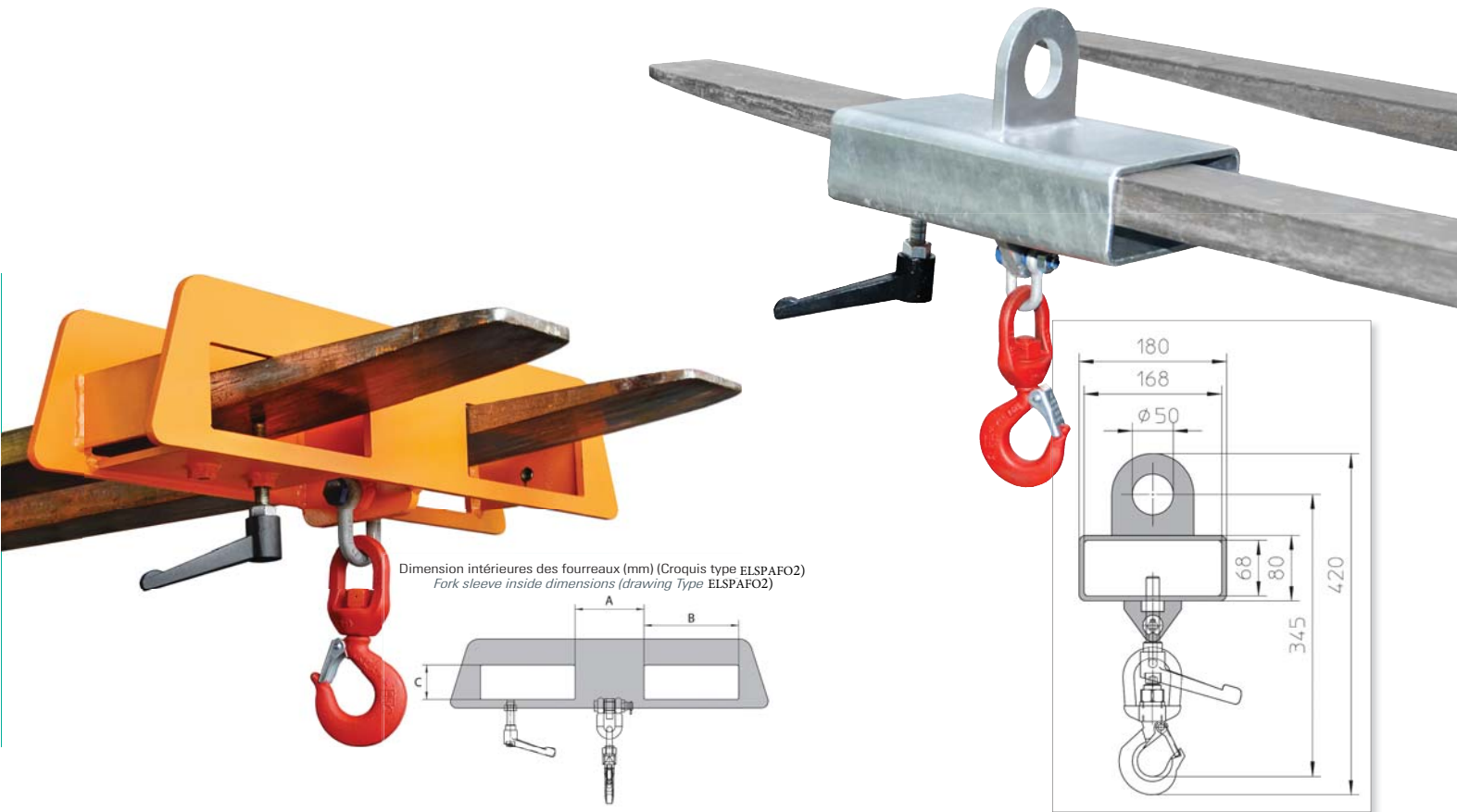

**Description**

Prise et transport de lourdes charges en toute

sécurité Type ELSPAFO1

- Prise pour 1 fourche et grue.
- Sécurisé contre le glissement inintentionnel.
- Avec crochet.
- Charge admissible 1 000 kg.

Type ELSPAFO2

- Prises pour 2 fourches (compatibles gerbeurs).
- Sécurisé anti-glissement pour différentes longueurs de fourches.
- Avec crochet à emerillon et linguet de sécurité.
- Charges admissibles différentes.

**Description**

Secure pick-up and transport of heavy duty goods

Type ELSPAFO1

- Suitable for 1 fork sleeve or crane.
- Can be secured to prevent slipping.
- With rotating hook.
- Load capacity 1 000 kg.

Type ELSPAFO2

- Suitable for 2 fork sleeves (also for straddle stackers).
- Can be secured to prevent slipping for different breadth of forks.
- With rotating hook.
- Different load capacities.

Type	CMU	Dimension (LxPxH)	Poids laqué	Dimensions intérieures des fourreaux		
				Dimension		
Type	Max capacity	Dimension	Weight	A	B	C
	m	mm	Kg	mm	mm	mm
ELSPAFO1	1000	300 x 180 x 325	10	-	168	68
ELSPAFO2 1,5	1500	170 x 750 x 360	21	160	220	80
ELSPAFO2 2,5	2500	170 x 750 x 390	22	160	220	80
ELSPAFO2 5,0	5000	180 x 750 x 460	31	160	220	80
ELSPAFO2 7,5	7500	180 x 750 x 510	35	160	220	80

**OPTIONS**

Peinture | *Painting*

RAL 2000 | RAL 2000

Galvanisé | *Galvanized*

# C LIFTING HOOK FOR PALLET



Type ELSPAFOM



Type ELSPAFOA

## Description

Les fourches de chargement sont des auxiliaires indispensables à la manutention de palettes, conteneurs et boîtes grillagés

- Fourches réglables.
- Hauteur utile réglable.
- Fourches noires.
- Surface laquée RAL 2000.

### Type ELSPSFOM

- à équilibrage manuel.

### Type ELSPAFOM

- Auto-équilibré.

## Description

Loading forks are indispensable aids for handling pallets, containers and pallet cages

- Adjustable forks.
- Adjustable usage height.
- Fork sleeve in black.
- Spray painted RAL 2000.

### Type ELSPAFOM

- Manual load counterbalancing system.

### Type ELSPAFOA

- Automatic load counterbalancing system.

Type	CMU	Hauteur utile min / max	Longueur des fourches	Section des fourches (PxH)	Écartement des fourches rebord ext. / rebord int. min / min	Poids Type M / Type A
Type	Max capacity	Usage height min / max	Length of forks	Cross section forks (w x h)	Dimensions over forks min. / max	Weight Type M / Type A
	Kg	mm	mm	mm	mm	Kg
ELSPAFOM1000	1000	1100 / 1700	1000	120 x 40	395 / 965	115
ELSPAFOM1500	1500	1100 / 1700	1000	120 x 40	395 / 965	118
ELSPAFOM2000	2000	1100 / 1700	1000	130 x 50	415 / 965	218
ELSPAFOM3000	3000	1100 / 1700	1000	130 x 50	415 / 965	228

Type	CMU	Hauteur utile min / max	Longueur des fourches	Section des fourches (PxH)	Écartement des fourches rebord ext. / rebord int. min / min	Poids Type M / Type A
Type	Max capacity	Usage height min / max	Length of forks	Cross section forks (w x h)	Dimensions over forks min. / max	Weight Type M / Type A
	Kg	mm	mm	mm	mm	Kg
ELSPAFOA1000	1000	1100 / 1700	1000	120 x 40	395 / 965	117
ELSPAFOA1500	1500	1100 / 1700	1000	120 x 40	395 / 965	120
ELSPAFOA2000	2000	1100 / 1700	1000	130 x 50	415 / 965	220
ELSPAFOA3000	3000	1100 / 1700	1000	130 x 50	415 / 965	230